

外型尺寸圖

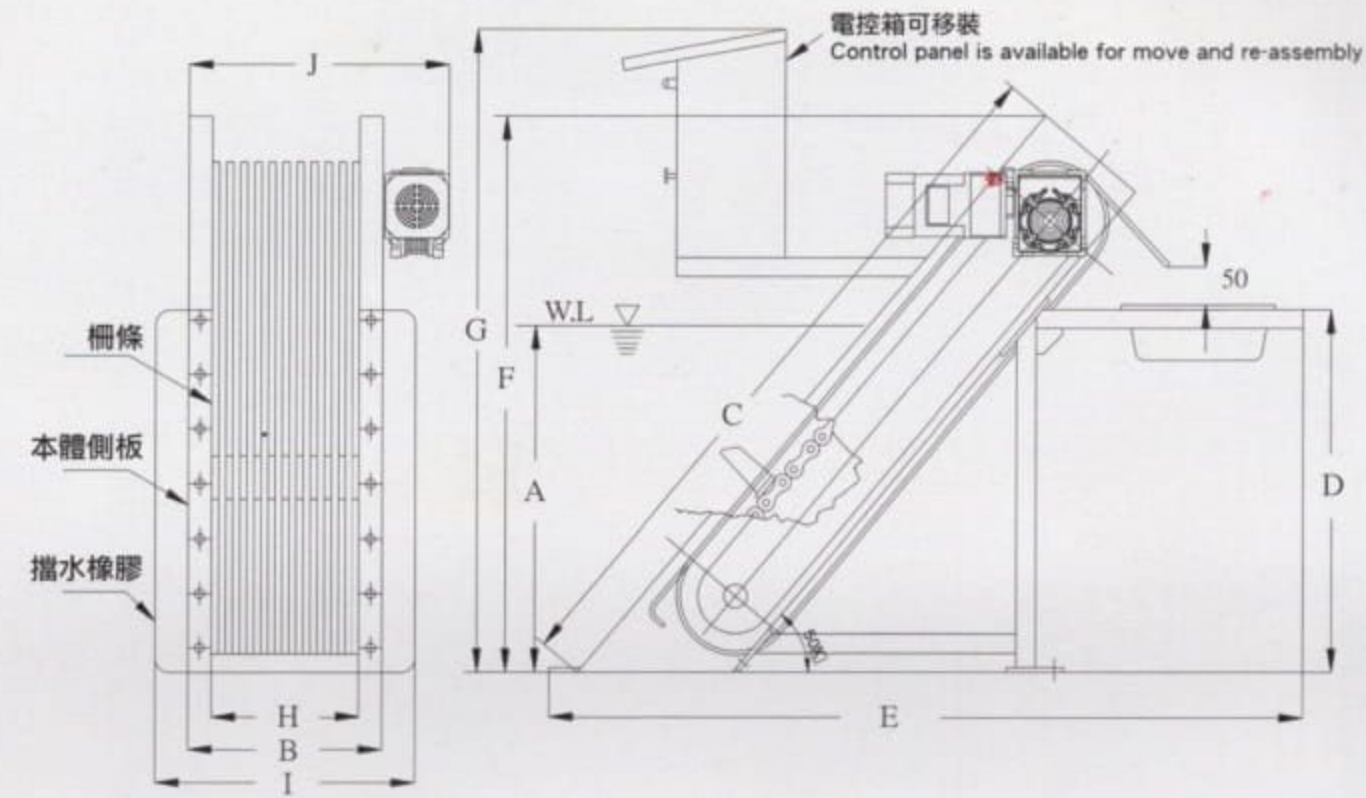

美國專利6309540號
US. PAT. NO.6309540
台灣專利172930號

機械式攔污柵 MECHANICAL BAR SCREEN

尺寸水量對照表

| 型號 | A 適用液面深度 最大MAX | B 適用水溝寬度 最小MIN | C | D | E | F | G | H | I | J | 縫隙 水量m ³ /hr | | | | | 備註 |
|-----------|----------------------|----------------------|------|------|------|------|------|------|------|------|-------------------------|-----|-----|-----|----|----|
| | | | | | | | | | | | 2 | 3 | 5 | 8 | 10 | |
| BS-3 x 5 | 500 | 300 | 1140 | 570 | 1300 | 980 | 1020 | 215 | 465 | 460 | 40 | 55 | 70 | | | |
| BS-5 x 5 | 500 | 530 | 1140 | 570 | 1300 | 980 | 1020 | 425 | 675 | 680 | 80 | 110 | 140 | | | |
| BS-7 x 5 | 500 | 750 | 1140 | 570 | 1300 | 980 | 1020 | 635 | 885 | 900 | 120 | 165 | 210 | | | |
| BS-3 x 10 | 1000 | 320 | 1860 | 1100 | 1800 | 1500 | 1520 | 215 | 465 | 470 | 100 | 130 | 170 | | | |
| BS-5 x 10 | 1000 | 550 | 1860 | 1100 | 1800 | 1500 | 1520 | 425 | 675 | 700 | 200 | 260 | 340 | | | |
| BS-7 x 10 | 1000 | 750 | 1860 | 1100 | 1800 | 1500 | 1520 | 635 | 885 | 920 | 300 | 400 | 500 | | | |
| BS-5 x 15 | 1500 | 550 | 2700 | 1600 | 2500 | 2400 | 2500 | 400 | 800 | 720 | 180 | 300 | 380 | 450 | | |
| BS-7 x 15 | 1500 | 750 | 2700 | 1600 | 2500 | 2400 | 2500 | 600 | 1000 | 920 | 250 | 400 | 530 | 600 | | |
| BS-9 x 15 | 1500 | 950 | 2700 | 1600 | 2500 | 2400 | 2500 | 800 | 1200 | 1130 | 300 | 500 | 650 | 800 | | |
| BS-11x15 | 1500 | 1150 | 2700 | 1600 | 2500 | 2400 | 2500 | 1000 | 1400 | 1130 | 400 | 650 | 800 | 950 | | |



型號多種無法詳載

鈺富機械有限公司
彰化縣員林鎮溝皂里溝皂巷16之7號
電話：04-8349555
傳真：04-8341504

JENFU MACHINERY CO., LTD.
No. 16-7, Kou-Tsao Lane, Kou-Tsao Li,
Yuah Lin Chen, Chang Hwa, Taiwan, R.O.C.
TEL : +886-4-8349555
FAX : +886-4-8341504
http : //www.jenfu.com.tw

經銷商 AGENT

1000.03.2007

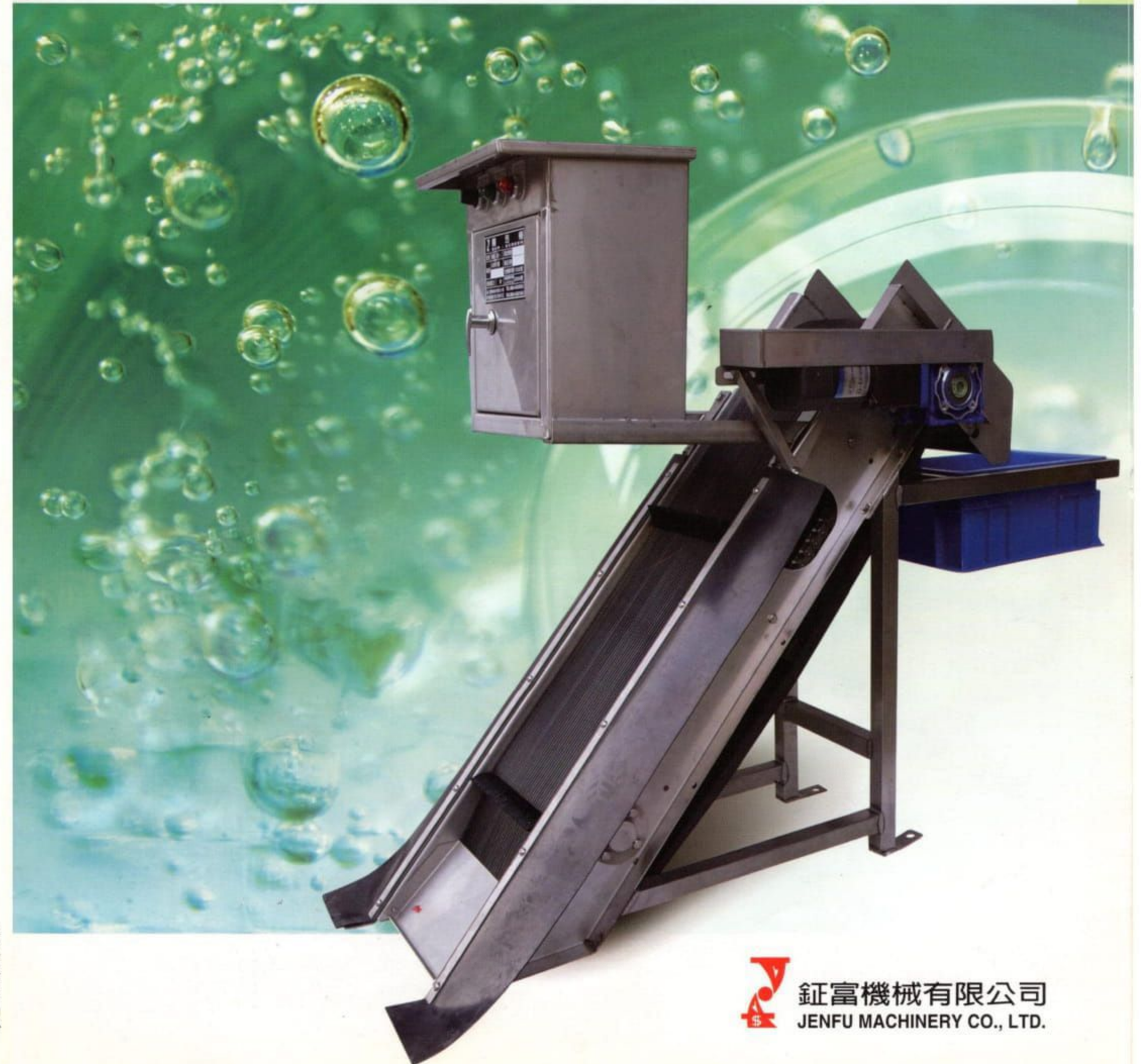

鈺富機械有限公司
JENFU MACHINERY CO., LTD.

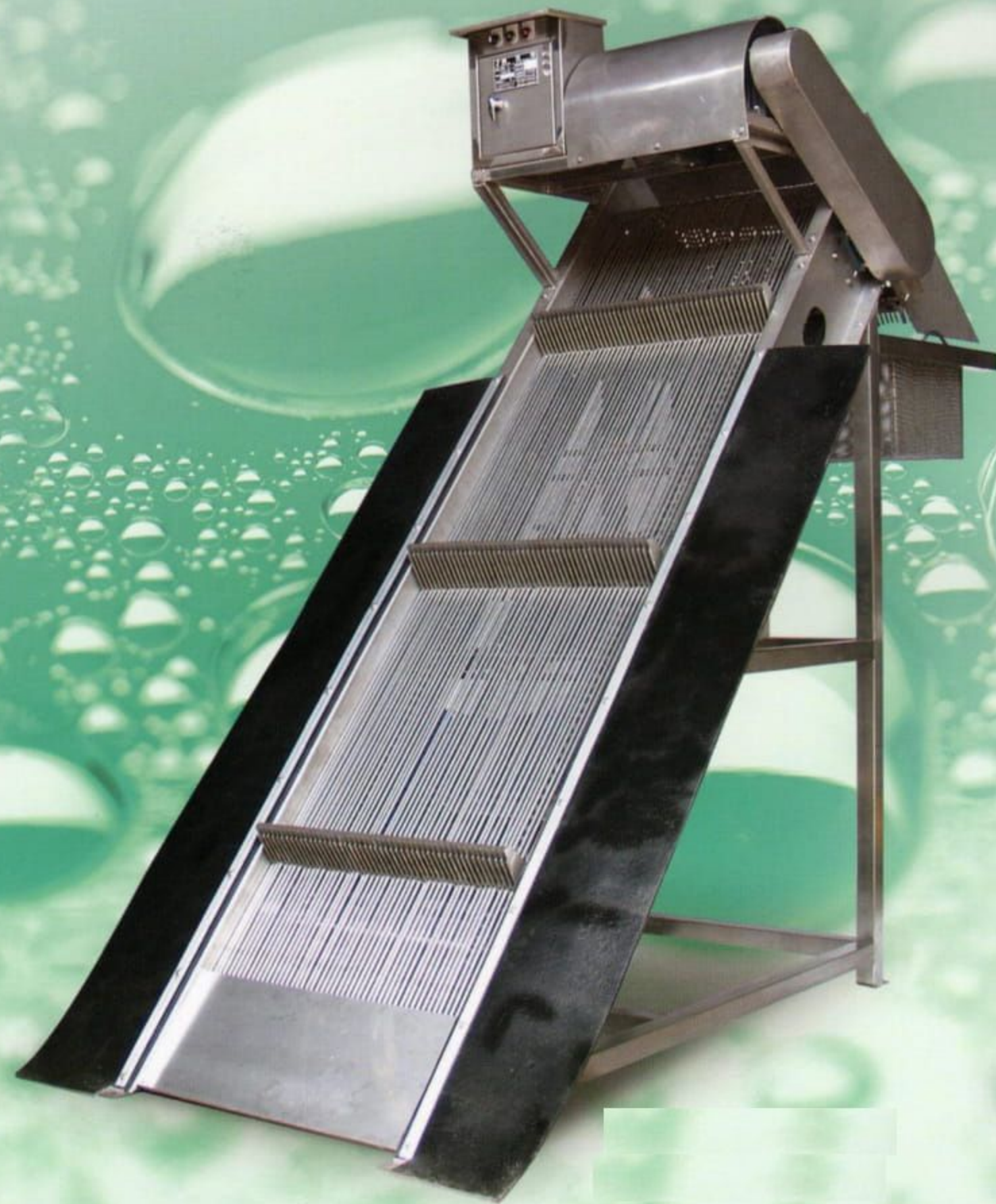

BS-3x10-2



BS-3x5-2

特點：

- 封閉O型柵條，非L型柵條，耙爪和柵條永不碰撞。
- 耙爪異物卡住時，安全梢自動切斷。
- 含電控箱，且馬達和電控箱有防雨保護。
- 永不阻塞，水流暢通無阻。
- 含24小時，時間比例控制。

Features :

- Olose O-type grating bars, not L-type grating bars. Harrow pawl and grating bars never hit each other.
- Safety pin breaks automatically if there is something blocked on harrow pawl.
- Never block, water flow is never stop
- Electric panel included, rainproof covers are provided to protect the motor and control panel.
- Timer control device for 24 hours.



舊有原理圖

Principle drawing of the old type:

L 形柵條
耙爪插入時有可能發生碰撞
L-type grating bars.
Hiting may be caused
while the harrow pawl
is inserting.

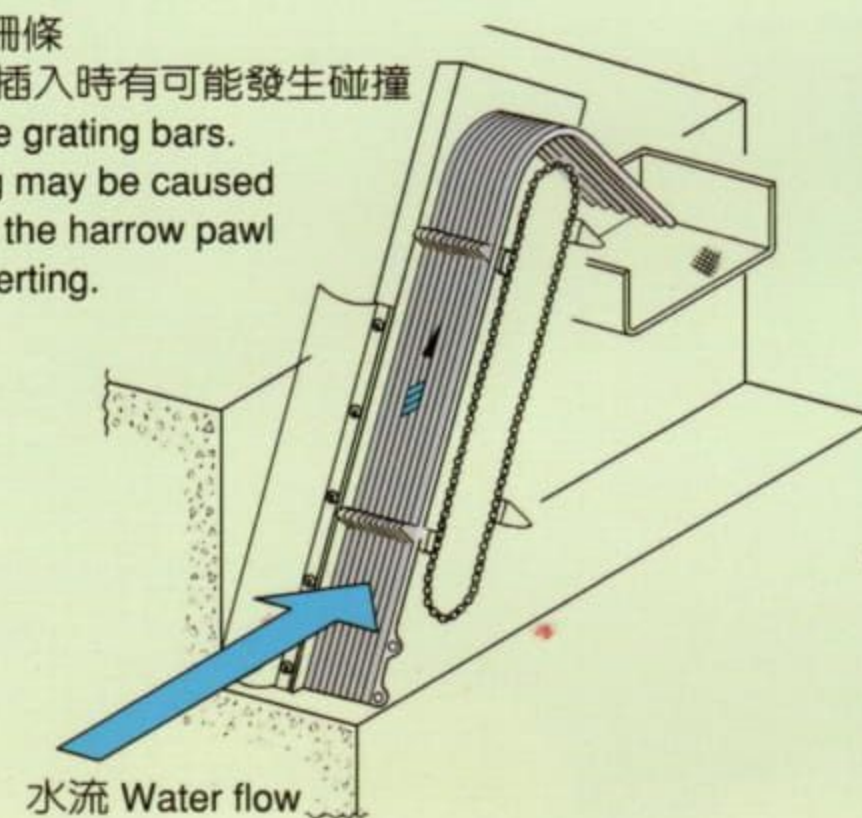

新開發原理圖

Principle drawing of the new developed product:

O 形柵條
耙爪無插入動作不碰撞
O-type grating bars.
No inserting on harrow
pawl, hiting will
not cause.

